



## Issaquah Highlands Data Network Specification Summary August 15, 2024

The bulk of the attached document (Exhibit “K”), outlines the requirements developers and builders in the Issaquah Highlands will need to comply with, to meet the needs of providing fiber optic service for the eventual customer to HFN.

The specific requirements differ for single family, townhome, apartment and business architecture.

1. Developers and builders of single family style homes are required to fulfill all items in the document, as the fiber optic cable itself shall be run from the connection point in the street to a structured wiring connection cabinet in the home. The HFN network is community owned, and needs to be built correctly to operate. Please pay special attention to section 4, which addresses inspection by our team. This allows us to be confident that our eventual customer can benefit from HFN’s fiber network.
2. Developers and builders of multiple development units such as townhomes or apartment style, need to place a conduit path from the street connection point to a utility closet or other location for eventual connection to CAT6 style distribution wiring. In this case, the fiber cable is pulled into this room, and electronic equipment is placed there. The builder would then provide CAT6 wiring to each individual unit, allowing for more than one service provider if needed. HFN only requires one CAT6 for this use. (Under certain conditions, the developer and HFN may decide to “Home Run”, or place fiber to each individual unit.)
3. Commercial property essentially only requires a conduit path from the street connection point to the building’s utility room. The developer would most likely also provide additional path to each suite, or business location.
4. Whenever facilities are placed in joint utility trenches, HFN advises that we inspect the structure prior to backfilling. HFN will respond to these situations ASAP.

As there are always changes in the industry in relation to vaults, conduit types and sizes, we at HFN are sensitive to these advances. Many times, the actual footprint for utility infrastructure is limited. HFN and our partners are always prepared to discuss and work with builders and developers to develop solutions that work for everybody. **We always encourage a “pre-construction” meeting with all parties prior to actual construction.**

#### Contact Information:

Jeremy Fallt, General Manager – HFN  
425-394-4184 or 206-321-0280 (Mobile), [jfallt@hfn.org](mailto:jfallt@hfn.org)

Shaun Sutter – Project Foreman – GigabitNow  
1-888-556-9711, [shaun@gigabitnow.com](mailto:shaun@gigabitnow.com)

**EXHIBIT K**  
**Issaquah Highlands Data Network Specification**  
**Revised March 27, 2014**

## **1. PURPOSE**

Community Fiber Networks and Highlands Council created the Highlands Fiber Network (“HFN”) and have installed area data centers, conduit and fiber-optic cable in joint utility trenches, and other related infrastructure across the area to serve residents and businesses in the Issaquah Highlands. The fiber network adds value to the development by enabling higher bandwidth for Internet access, telephone service and video delivery that would otherwise be unavailable to residents and businesses. The purpose of this document is to provide instructions and specifications to land developers (“The Developer”) and home builders (“The Builder”) on how to extend the fiber network into the residential neighborhoods and business units in the Issaquah Highlands. As additional structures are added to the area, it is necessary to coordinate the design and installation of conduit and fiber to area infrastructure. HFN will provide assistance to land Developers and Builders in planning the extension of the facilities, clarify requirements and coordinate schedules for fiber installation.

## **2. SPECIFICATIONS FOR DEVELOPER-PROVIDED INFRASTRUCTURE**

### **A. Main Backbone and Backbone Distribution System**

- i. The Developer will provide the main backbone and backbone distribution system.
- ii. Large Conduit/Duct. Large conduit shall be 4” industry standard DB 120 PVC pipe with integral bell (or better) with appropriate fittings. Pipe should be in accordance with TC-6 and ASTM F512 standards: O.D. 4.5”, I.D. 4.192” with minimum wall thickness .166”. Conduit is to be installed with the maximum bend radius possible with no 90-degree bends. Duct shall be placed with a minimum of 36” cover over the top of the highest duct. A 10 THHN locator cable shall be buried next to the conduit duct. Multiple levels of duct shall have spacers installed to maintain correct conduit location.
- iii. Small Conduit/Duct. 1” or 1 ¼” smooth walled polyethylene SDR-11 conduit pipe (or better) with appropriate fittings will be installed in a “quad” configuration of one or more units of 4 conduits per length of run. All conduits will have a pre-installed pull rope or tape. 1” nominal size: O.D. 1.055”, I.D. 1.315”, minimum wall thickness 0.120”. 1 ¼” nominal size: O.D. 1.338”, I.D. 1.660”, minimum wall thickness 0.151”. Conduit will be installed with the maximum bend radius possible with no 90-degree bends. Duct shall be placed with a minimum of 36” cover over the top of the highest duct. A 10 THHN locator cable shall be buried next to the conduit duct. Multiple levels of duct shall have spacers installed.
- iv. Precast Vaults. Vaults will be standard 48” x 48” x 48” deep communications vaults (Utility Vault Company 444-LA or equivalent). Vault covers will have a full 180 degree opening cover with spring assisted galvanized diamond plate covers with locking latch and a recessed lift handle (Utility Vault Company 44-332P or equivalent). Vaults will be set at grade level. Vaults must be placed upon a 4” sand/gravel drainage bed. Note: Some vaults will require pad-mounted equipment cabinets placed above the vault opening. Specifications for the placement and

installations of these vaults will be provided on a case-by-case basis by The Developer or their designated representative.

### **3. SPECIFICATIONS FOR HOME-BUILDER-PROVIDED INFRASTRUCTURE**

All work will comply with applicable building and electrical codes, as well as ANSI/TIA/EIA 568A, 570A and 758 (latest revision, see TABLE 2).

#### **A. Service Distribution System**

The service conduit coming from the street shall enter the building either through the foundation (preferred) or through an approved external junction box. Due to the nature of different residential areas in the Issaquah Highlands in-ground junction boxes may be superseded by an above ground pedestal unit as determined by HFN at the preliminary construction meeting for the build. In-home conduit shall be used to extend service conduit from the Service Entrance to the Central Communication Distribution Panel located at the Main Distribution Location (MDL) for the home.

- i. The Builder must install a Carson Ind. Series 910 junction box or pre-approved equivalent junction box (Refer to standard detail). This type of junction box allows HFN and the Builder to have a definitive delineation of responsibility, one tie-in point, and a reduction in conduit “dig-ups.” The Carson/junction box lid must be ordered with “Fiber” permanently stamped on it.
- ii. The Builder must install a fire-rated single 1-1/4” flexible continuous service conduit to enter the home either through the foundation or through an approved external junction box. Location shall be determined in the field and coordinated between the Builder and HFN or their designated representative.
- iii. Jet line or pull rope is mandatory and must be tied-off in a manner that restricts the jet line from being pulled back through the conduit. If the jet line is missing or has not been installed in the service conduit by the Builder, then HFN will not be able to provide service immediately. HFN will not return until the Builder has rectified the problem. Once the jet line is installed, the Builder must call HFN to return. Jet line or pull rope is required in all conduits, including, but not limited to those that lead to the attic, in the crawlspace, and from the Carson box to the house.
- iv. The builder is responsible for having a clear path in their conduit.
- v. Service conduits coming from the backbone distribution system shall maintain the separation from power conduits or cables required by the local power company, preferably a minimum of 12”.
- vi. Communication service conduit must be installed a minimum of 18 inches underground. A 3” wide orange warning tape shall be buried at least 12” below ground level and approximately 6” over the conduit ducts.
- vii. Communication service conduit shall have watertight connections and be sloped properly so water will drain away from the home entrance.
- viii. All Service Distribution System conduits shall be labeled identically at both ends with a unique identification utilizing permanent ink.
- ix. Highlands Fiber Network, or their designated representative, will install fiber cable from the backbone distribution system to the central communications distribution panel using the service conduit when the network is installed.

## B. Residential Structured Wiring System

All work will comply with applicable building and electrical codes, as well as ANSI/TIA/EIA 568A, 570A and 758 (latest revision, see TABLE 2).

- i. The CDP is the distribution point for all horizontal data cable in the structure. The CDP shall be an OnQ model #363475-01 (28”h x 14.25”w x 4”d) or pre-approved equivalent with hinged door. Provisions are also made within this panel for the termination of telephone and video cables only, security systems, or other 3<sup>rd</sup> party devices are not permitted.
- ii. The Communications Distribution Panel should be centrally located within the structure. Suitable locations include basements, closets, under stairwells, and in utility rooms. An attic is not a suitable place. Placement should allow easy access for the customer as well as service personnel. Two panels, interconnected by 2” conduit, should be installed to accommodate structured wiring for dwellings over 4,000 square feet. See drawing of CDP on the next page.
- iii. The CDP shall be installed where the normal ambient temperatures do not go below 32 degrees F, or above 110 degrees F.
- iv. One (1) dedicated 110VAC / 15-amp, non-GFCI, electrical circuit shall be installed inside the communication distribution panel. The circuit is required for data service and communication equipment supplied by the HFN and exclusively for this equipment. The circuit shall be terminated in a duplex electrical receptacle.
- v. The data panel location shall have at least (1) one additional duplex electrical outlet nearby for tools, diagnostic and test equipment. This outlet can be part of a shared 20-amp circuit.
- vi. All equipment shall be grounded according to TIA/EIA-607 standards for grounding, and electronically isolated from one another.
- vii. The builder will run the conduit all the way into the CDP.
- viii. Each Home will have its own service conduit.
- ix. The Builder must run a spare service conduit from the CDP to the attic or crawl space to ensure that the future homeowner will have the ability to run additional data lines.
- x. Individual Category 5e cables from RJ45 data and telephone jacks in the living/user areas shall be terminated in the central communications distribution panel with single male RJ45 connectors, or to a patch panel. The Category 5e data cables must be clearly coded, tagged, and bundled at the data panel. Category 6 data cables may be used instead of Category 5e.
- xi. A service loop of 24” (minimum) shall be neatly looped and secured within the central communications distribution panel.
- xii. All installations shall conform to the latest ANSI/TIA/EIA/568A and 570A standards (see TABLE 2).

# COMMUNICATION DISTRIBUTION PANEL AND CONNECTING HARDWARE COMPONENT LOCATIONS

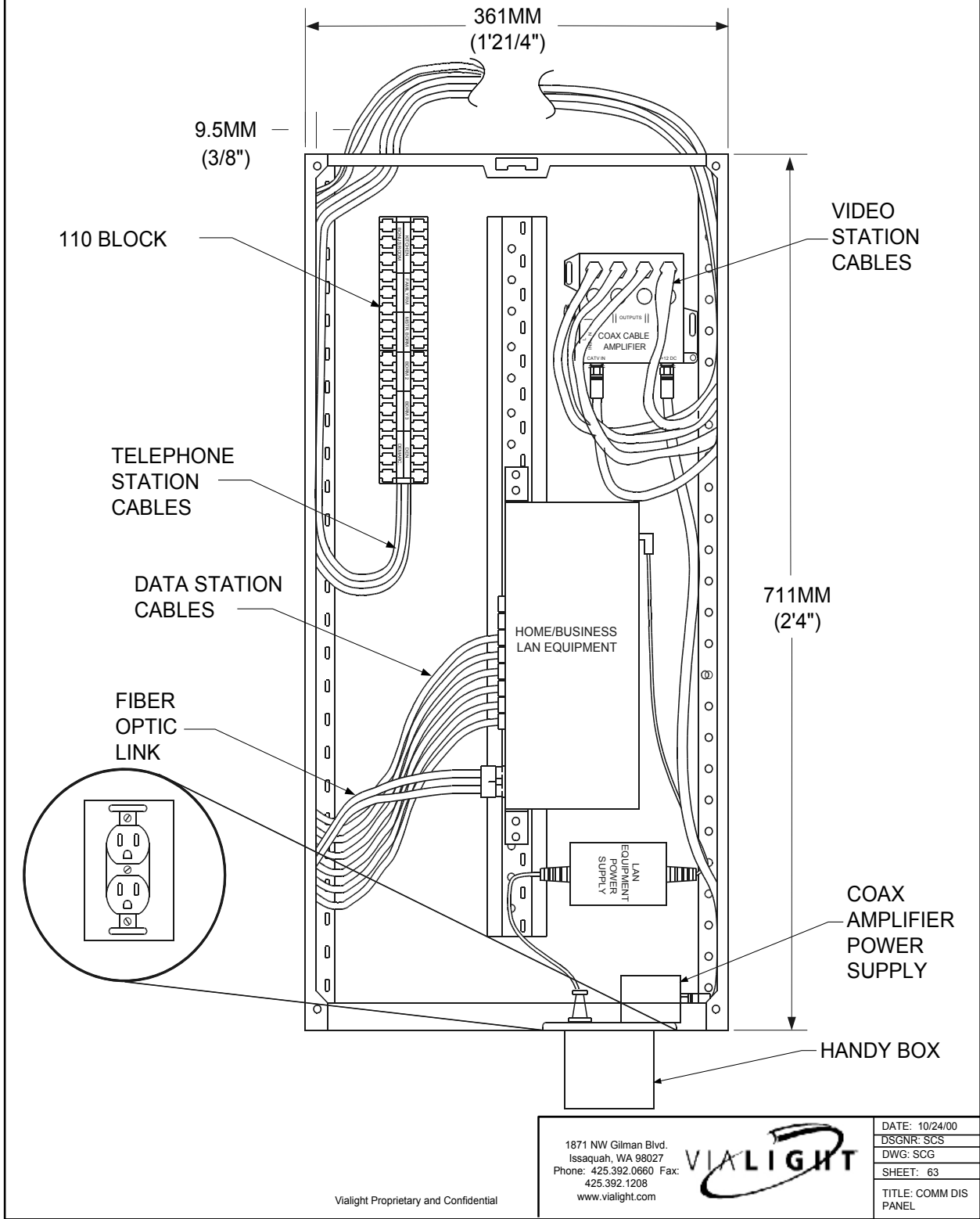

### C. Equipment Rooms for Multi-family buildings

Equipment rooms or communications closets are special-purpose rooms that provide space and a suitable operating environment for communications and/or computer equipment, and will be provided with sufficient space to house standard 19" equipment racks and sufficient working space. Provision should also be made for the installation of a backboard for equipment mounting. The Builder should coordinate the design with HFN or its representative. Equipment rooms should be furnished with the following:

- i. Power. Dedicated 110VAC / 20-amp, non-GFCI, power terminated on 4-plex outlets to be used for HFN purposes exclusively.
- ii. Lighting. Sufficient lighting for a normal working environment.
- iii. HVAC The equipment rooms or communications closets shall have normal ambient temperatures maintained between 32 degrees F and 110 degrees F.
- iv. Inside Service Conduit with jet lines shall be run from each residence's CDP to an equipment room. The maximum length for an Inside Service Conduit run is 100 meters. Multiple equipment rooms may be required in large structures to comply with this distance limitation.
- v. Minimum diameter 2" service conduit must be run from the service entrance of the structure to the equipment room. If multiple equipment rooms are required, additional 2" service conduit must be run between each equipment room.

### D. High Speed Data Cables

Data cables will be extended between the central communications distribution panel and associated data outlet jacks and will consist of Category 5e, 4 pair UTP, or Category 6 UTP, 4 Pair and shall be terminated on 8 pin modular jacks provided at each outlet in the T568A configuration. Cable jacket shall comply with Article 800 of the NEC for use as plenum or non-plenum cable.

- i. Terminations. Cables shall be marked with wire markers at both ends, and terminals on terminal blocks shall bear the cable number. Trunk cables shall be neatly marked with "From-To" information. Wire twist shall be maintained to within 0.25" of the terminal block fingers.
- ii. Cable. All 4 pair Category 5e cables shall conform to ANSI/TIA/EIA 568-A Commercial Building Telecommunications Cabling Standard, Horizontal Cable Section, and be part of the UL LAN Certification and Follow-up Program. Applications standards supported should include, but should not be limited to, 1000BASE-T, and shall meet or exceed the electrical and mechanical specifications for Category 5e per ANSI/TIA/EIA 568-A and associated technical service bulletins (TSBs).
- iii. A service loop of 24" (minimum) shall be neatly looped and secured within the central communications distribution panel.
- iv. An un-connectorized (dark), 2-strand single-mode fiber optic cable may optionally be run parallel to, and along with, each Category 5e data drop cable for future accessibility.
- v. The Category 6 UTP specification is TIA/EIA-568-B.2-1.

#### E. Data and Telephone Outlets

- i. Faceplates shall be available in single, duplex, triplex, quad-plex, or six-plex arrangement in a single gang configuration. At the Builder's option, data faceplates can be combined for data, voice, and cable applications.
- ii. Surface mount boxes shall be available in single, dual, quad, and six-plex configurations.
- iii. Communications outlets shall consist of one, two or three gang utility outlet boxes with cover plates designed to accept RJ-45 jacks, utilizing the T568A termination style.
- iv. Outlets shall be provided with blank module inserts for all unused module locations.
- v. Low voltage wiring or devices shall not occupy the same wiring channel as high voltage wiring or devices.
- vi. Category 5e Jacks
  - a) All Category 5e Jacks shall conform to ANSI/TIA/EIA 568-A Commercial Building Telecommunications Cabling Standard, Horizontal Cable Section along with Technical Service Bulletins (TSBs), and be part of the UL LAN Certification and follow-up program.
  - b) All Category 5e jacks will be wired with a T568A wiring configuration.
  - c) Category 6 jacks are required for use with Category 6 cabling.

#### F. Cable Installation

- i. Follow cable manufacturer's specification regarding handling methods, retaining/support methods, bending radius and maximum pulling tension limitations.
- ii. Telecommunication cables shall not be installed in the same raceway as power cables. Cables shall maintain a minimum separation of 12" from high voltage cables and only cross high voltage cables at right angles.
- iii. Cables placed in cable trays shall be installed in a neat and orderly manner and shall not cross or interlace other cables except at breakout points.
- iv. Cables in vertical trays shall be individually retained with straps at a maximum of 6' on center.
- v. Tie-wraps shall not deform the cable insulation when tightened.
- vi. All cables shall be identified with a permanent label. Identical information shall appear at each end of all cables. Inside plant cables shall be labeled with room designations. Feed and outside cables shall be labeled with unique street addresses of unit being served. Labels shall be machine generated or otherwise extremely legible.
- vii. Fire stopping material shall be applied at appropriate locations throughout the system in order to fully conform to applicable standards, codes and ordinances.
- viii. Installation shall be warranted by the Builder for a period of one year after acceptance of the installation. It shall be the responsibility of the Builder to repair any faulty installation component(s) within one year at no additional cost to The Developer or Homeowner.

- ix. All cables shall be routed to minimize EMI and RFI interference. All cable shall be routed according to the attached Table 1. Spacing is minimum.

#### G. Cable Testing

The entire Category 5e or Category 6 cabling system, including all jacks in the home shall be tested with a level II (minimum) cable tester to the highest standard officially recognized by ANSI/TIA/EIA. Tests performed shall include wire map, length, propagation delay, delay skew, attenuation, NEXT, ELFEXT (pair-to-pair as well as Power Sum), and return loss. Test results shall include all test data results and a statement of compliance (pass/fail).

#### H. Documentation

Items to be provided to Highlands Fiber Network or their designated representative upon completion of low voltage installation:

- i. Category 5e or Cat 6 test results (printed or compliant electronic file) sorted according to (a) address, (b) outlet and (c) link. Compliant file types are ones reviewable without additional proprietary software.
- ii. A legible and accurate listing of all cables must be submitted along with the aforementioned test results. The listing must detail all cable runs, cable lengths, room names, and wire numbers.

#### I. Certification

Builders shall provide documentation that the wiring meets the specifications called out in this document. Cables or jacks not passing testing shall be repaired or replaced at Builder's expense. Certification of installed wiring shall be delivered to Highlands Fiber Network or its representative after successful completion of installation, required testing and documentation, but at least 15 days prior to occupancy date. At HFN's option, HFN, or its designated representative, will provide certification services at Builder's expense.

#### J. Inside Wiring Distribution Points

All Master Bedrooms, Kitchens, and Office/Dens will be wired and terminated with:

- i. Data - one (1) Category 5e cable.
- ii. Video - one (1) RG 6 - "F" style Compression connectors.
- iii. Telephone - one (1) Category 5e cable.

Additionally, Living Rooms and Entertainment Centers shall be wired and terminated with:

- i. Data - one (1) Category 5e cables.
- ii. Video - two (2) RG 6 - "F" style Compression connectors.
- iii. Telephone - one (1) Category 5e cable.
- iv. One (1) flexible conduit to the attic and/or crawl space.

Distribution outlets shall be located as shown on the home plans, as specified in the construction documents or as otherwise directed.

#### K. Wiring for Telephone Service

Every telephone termination point provided in the home must be fully faceplate terminated to RJ-45 and must be terminated to the Telephone Termination Block.

Every telephone outlet in the home is required to be “Active” for lines 1 through 4.

RJ-45 Termination Option: If the telephone termination points are RJ-45 jacks, then EACH RJ-45 jack MUST be appropriately color coded and clearly labeled for “TELEPHONE” or “DATA.”

If the telephone termination points are RJ-45 jacks, then they must be able to be fully provisioned with external-to-the jack line selectors, line splitters, dongals, or similar devices, to receive RJ-11 male line jacks, for all 4 active telephone lines.

Builders using the RJ-45 Termination Option are required to provide the following components, services, and warranties to their Residents:

- i. The Builder will provide information such that residents can obtain external-to-the jack line selectors, line splitters, dongals, or similar devices, to receive RJ-11 male line jacks, on all 4 lines provided. This information must be provided before or at initial Resident Move-In.
- ii. The Builder must include, at a minimum, the following written and receipted disclosure to the initial Residents – “Using an RJ-45 Jack, Identified as TELEPHONE, for DATA use, may cause significant damage to the DATA equipment connected.”

#### L. Laboratory Listing

Where a Nationally Recognized Testing Laboratory (NRTL) listing or classification exists for a product and the product is suitable for the purpose specified and indicated, the product shall bear the appropriate marking indicating the listing or classification. Where a UL Standard is in effect, equipment shall a) meet that standard and b) bear the UL Label.

#### M. Other Components

Any item of equipment not specifically addressed in this document and required to provide a complete and functional installation shall be provided at a level of quality consistent with other specified items.

#### N. Requirements for Complete System

Minimum system requirements as set forth in these specifications shall consist of the required components including but not limited to all cable, wire, distribution panels, application outlets, accessories and other components required for a complete and operable system.

#### 4. INSPECTION AND TESTING

For each unit, HFN will conduct **two (2)** inspections that must be passed:

##### A. Rough-in inspection

Rough-in inspection will be done prior to the fiber being pulled in to the CDP. This means that the Builder must notify HFN after the low voltage wiring has been completed and before sheet rock is installed. This will help ensure that all cabling for Data, Video and Telephone have been properly installed to all designated locations.

##### B. Trim-out inspection

Trim-out inspection is required to ensure that all data lines have been punched down correctly and proper connectors have been installed. The low voltage trim-out inspection is done after the low voltage wiring has been terminated, trimmed-out and dressed. This must be performed in accordance with the inspection schedule and at least 2 weeks before occupancy.

##### C. Inspection Requests

Builders are to request inspections one week in advance, using the website below:

<https://www.highlandsfibernetnetwork.com/Builders/>

If there are problems entering the request, the builder can click on the “Contacts” tab and send the request via email.

The Builder or a representative for the builder must be present during each inspection and will be required to sign each inspection form. If an inspection has failed, the Builder and the inspector will set a re-inspection date at least 2 weeks prior to occupancy. The Builder will have until the re-inspection date to resolve any and all problems found.

##### D. Inspection Fee

If an inspection has failed, the Builder and the inspector will set a re-inspection date. The Builder will have until the re-inspection date to resolve any and all problems found. The Builder will be billed \$150 for *each* return for re-inspection. This will also apply to conduit problems. A trip charge of \$150 will be charged to the Builder each time that an HFN contractor must return to a home that is not ready. **Failure to schedule inspections in allotted timeframe will result in a \$500 fine. Failure to submit Cat 5 certification in allotted timeframe will result in fines up to \$500.**

##### E. Inspection Emphasis

Special emphasis will be placed on inspecting the model homes and the early production homes, in the beginning of each Model Phase or Construction Phase. The purpose is to identify, as early and completely as possible, any design issues, installation issues, or other issues, related to that floor plan, before it goes in to the Production Phase. For this purpose the Inspector will meet with the Site Superintendent and the Low Voltage Cabling Contractor on the job site prior to the system being installed. This will be a one-time meeting to allow everyone to start off with the same understanding of the specification and how it may apply to each dwelling type. Once under construction, all homes will be inspected. Site Superintendent and the Low Voltage Cabling Contractor are preferred to attend the scheduled inspections, however it is not mandatory

## F. Inspection Results

All homes inspected will receive a report accessible at the web site address provided above, indicating “Pass”, or “Fail”, based upon the Inspector’s professional judgment.

**Homes receiving a “Fail” on Pre-Wire Inspection, must be corrected, and re-inspected, with-in one week. This remedial inspection must be PRIOR to insulation.**

Homes receiving a “Fail” on Trim-Out Inspections, must be corrected, and re-inspected, with-in Five (5) working days. This remedial inspection must be PRIOR to Home Owner Move-In Inspection and to Homeowner Move In.

The cost of remedial or subsequent inspections, by HFN, is a Developer/Builder cost.

SWS inspections and testing will normally be done after notification to the Builder. The Builder, normally through their Site Superintendent, is responsible to notify the Inspector, of an appropriate time, and date when the inspection can be completed.

A copy of the inspection reports will be provided to Builder Representative, after the inspection is complete.

The cost of the initial SWS inspections is normally an HFN cost. If such initial inspection is not possible due to Builder delay, or incorrect scheduling, it is a Builder cost.

## 5. LOW VOLTAGE CABLING CONTRACTOR (LVCC)

The Builder, through their LVCC, is responsible for the correct installation, testing, and warranty, of all installed SWS cabling, and components, within the home premises. The Builder must carefully select their LVCC to insure their capability, to correctly install, maintain, change, upgrade, update, and warrant the SWS, in full compliance with all the specific codes, standards, and requirements, of this low voltage application.

Specific responsibilities of the Builder, through their LVCC, include, but are not limited to:

- i. Pre-wiring of all required wire, cable, and pre-wire installation hardware, including brackets, enclosures, back boxes, etc.
- ii. Termination and labeling of all wire and cabling
- iii. Detailed visual inspection of all installed low voltage cable, to confirm the minimum required offsets, from line voltage cable, are achieved
- iv. Testing of all wire and cable runs for opens, shorts, crossed pairs, etc.
- v. Testing of all wire and cable runs for throughput, if required by HFN, Builder, or other entity
- vi. Installation and testing of all distribution electronics (active and passive)
- vii. Proper trim out of all Telecommunications Service Outlet (TSO) locations, including plug inserts, faceplates, etc.
- viii. Providing accurate, as-built documentation (wiring lists, drawings etc.), of the completed installation
- ix. Providing warranty that all installed SWS cabling, enclosures and system components, meet or exceed the requirements, of the UBC, UL, local codes, the

- ANSI/TIA/EIA-570-A Residential Telecommunications Cabling Standard, the Original Equipment Manufacturer(s), and the SWS
- x. Providing warranty that all installation procedures, meet or exceed the requirements, of the UBC, UL, local codes, the ANSI/TIA/EIA-570-A Residential Telecommunications Cabling Standard, the Original Equipment Manufacturer(s), and the SWS
  - xi. Complete and professional correction of any identified SWS deficiencies

## **6. BUILDER OR BUYER OPTIONAL EQUIPMENT**

The Issaquah Highlands Exhibit K specifically does not provision:

- Satellite Reception of Television or Other Signal
- Off-air Reception of Television or Other Signal
- Security Wiring
- Security Systems
- Distributed Audio
- Entertainment Systems or Distribution
- Home Automation or Control
- Smart Appliances
- Home Gateway Functionality
- Firewalls
- Routers
- Wireless Systems
- Any Other Resident Optional Home Systems
- In-home Local Area Networking of computers

The term “**Provider**” means the entity that is responsible to provide the specified component and to pay for it. The term “**Alternate Provider,**” if any, means the entity that, at their discretion, may elect to assume this cost from the “Provider,” subject to all other SWS requirements.

## 7. MINIMUM SEPARATION REQUIREMENTS FOR BUILDERS

TABLE 1

Minimum Separation of Telecommunications pathways from 480 volt or less power lines

Condition	<2 kVA	2-5 kVA	>5 kVA
Unshielded power lines or electrical equipment in proximity to telecommunications open or nonmetal pathways.	5 in	12 in	24 in
Unshielded power lines or electrical equipment in proximity to telecommunications grounded metal conduit pathways	2.5 in	6 in	12 in
Power lines enclosed in a grounded metal conduit (or equivalent shielding) in proximity to a telecommunications grounded metal conduit pathway	N/A	3 in	6 in
Power lines enclosed in a grounded metal conduit (or equivalent shielding) in proximity to telecommunications open or nonmetal pathways.	2.5 in	6 in	12 in
Mechanical ductwork, metal floors and other metallic planes to telecommunications open or nonmetal pathways.	2 in	N/A	N/A
Mechanical ductwork, metal floors and other metallic planes to telecommunications open or grounded metal conduit pathways.	0 in	N/A	N/A
Fluorescent or HID lighting fixtures	5 in	5 in	5 in

## 8. REFERENCE CODES AND STANDARDS

The publications listed below form a part of this specification to the extent referenced. The publications are referred to in the text by basic designation only, latest edition. The reference codes and standards are minimum requirements.

TABLE 2

<b>Reference</b>	<b>Title/Revision</b>
ANSI/ICEA S-80-576	Communications Wire and Cable for Wiring of Premises
ANSI/ICEA S-83-596	Fiber Optic Premises Distribution Cable Technical Requirements
ANSI/ICEA S-87-640	Fiber Optic Outside Plant Communications Cable
ANSI C2	National Electrical Safety Code
ANSI/NFPA 70	National Electrical Code
ANSI T1.318	Electrical Protection Applied to Telecommunications Network Plant at Entrances to Customer Structures or Buildings
ANSI/TIA/EIA-568-A	Commercial Building Telecommunication Cabling Standard (October 1995)
ANSI/TIA/EIA-569	Commercial Building Standards for Telecommunications Pathways and Spaces (October 1990)
ANSI/TIA/EIA-570A	Residential Telecommunications Cabling Standard
ANSI/TIA/EIA-571	Environmental Considerations for Telephone Terminals
ANSI/TIA/EIA-606	Administration Standard for the Telecommunications Infrastructure of Commercial Buildings (February 1993)
ANSI/TIA/EIA-607	Commercial Building Grounding and Bonding Requirements for Telecommunications
ANSI/TIA/EIA-758	Customer-Owned Outside Plant Telecommunications Cabling Standard
ANSI/TIA/EIA-TSB 67	Transmission Performance Specifications for Field Testing of Unshielded Twisted-Pair Cabling Systems (October 1995)
ANSI/TIA/EIA-TSB 72	Centralized Optical Fiber Cabling Guidelines (October 1995)
ANSI/TIA/EIA-TSB 95	Additional Transmission Performance Guidelines for 4-pair 100 Ohm Category 5 Cabling
BICSI TDMM	Telecommunications Distribution Methods Manual
BICSI CO-OSP	Customer Owned Outside Plant Design Manual

**EXHIBIT K - Additional Detail**  
**Issaquah Highlands Data Network Specification – Commercial Properties**  
**Revised March 27<sup>th</sup>, 2014**

Community Fiber Networks and Highlands Council created the Highlands Fiber Network (“HFN”) and have installed area data centers, conduit and fiber-optic cable in joint utility trenches, and other related infrastructure across the area to serve residents and businesses in the Issaquah Highlands. The fiber network adds value to the development by enabling higher bandwidth for Internet access, telephone service and video delivery that would otherwise be unavailable to residents and businesses. The purpose of this document is to provide instructions and specifications to land developers (“The Developer”) and home builders (“The Builder”) on how to extend the fiber network into the residential neighborhoods and business units in the Issaquah Highlands. As additional structures are added to the area, it is necessary to coordinate the design and installation of conduit and fiber to area infrastructure. HFN will provide assistance to land Developers and Builders in planning the extension of the facilities, clarify requirements and coordinate schedules for fiber installation.

**Main Backbone Distribution System**

This distribution system consists of conduit, vaults, and building/division electronics centers for the distribution of communications media throughout the Project, connecting a central content and hosting center to all individual commercial properties. The Network will be installed to insure that all properties within the development will have access to advanced communications capabilities. The Developer will bear the costs for creation of the Main Backbone Distribution System.

The Main Backbone Distribution System consists of the following components:

- A. Vaults. 48” x 48” x 48” deep communication service and distribution vaults will be installed at appropriate intervals along all major arterials within the Project. These underground vaults serve as access and connection points to the Commercial Backbone Distribution System for the installation and service of communications media. The vaults will be connected using underground conduit from vault to vault throughout the project. Vaults shall be located within designated areas.
- B. Conduit. One or more groupings of (4) 1” innerducts, and one 4” empty conduit will be installed parallel to all other communications improvements, connecting each vault, making a continuous path from the last vault installed to the content and hosting center. Additional conduit may be installed to increase capacity.
- C. Specifications. The Developer, or a designated representative, will provide installation and design specifications for the installation of the Main Backbone Distribution System. Instructions for connecting each commercial property to the Main Backbone Distribution System will be provided to the Builder.
- D. It shall be the responsibility of The Developer to install conduit up to the property line for each subdivision. It shall be the responsibility of the Builder to install and connect conduit from the property line to every individual commercial unit.

**1. COMMERCIAL BACKBONE DISTRIBUTION SYSTEM**

This distribution system is an extension of the Main Backbone Distribution System and consists of conduit and vaults connected to the nearest Main Backbone Distribution System.

The Commercial Backbone Distribution System consists of the following components:

- A. Vaults. 48" x 48" x 48" deep communication service and distribution vaults will be installed at appropriate intervals along all arterials within the Project. These underground vaults serve as access and connection points to the Commercial Service Distribution System for the installation and service of communications media. The vaults will be connected using underground conduit from vault to vault throughout the project. Vaults shall be located within sidewalks, wherever possible. The Developer will bear financial responsibility for the Vaults.
- B. Conduit. One or more groupings of (4) 1" innerducts, and one 4" empty conduit will be installed parallel to all other communications improvements, connecting each vault in turn making a continuous path from the last vault installed to the Main Backbone Distribution System connecting vault. Additional conduit may be installed to increase capacity. The Developer will bear financial responsibility for the Conduit.
- C. Specifications. The Developer, or a designated representative, will provide installation and design specifications for the installation of the Commercial Backbone Distribution System. Instructions for connecting each commercial property to the Commercial Backbone Distribution System will be provided to the Builder.
- D. It shall be the responsibility of The Developer to install conduit up to the property line for each subdivision. It shall be the responsibility of the Builder to install and connect conduit from the property line to every individual commercial unit.

## **2. COMMERCIAL SERVICE DISTRIBUTION SYSTEM**

This distribution system consists of conduit from the closest Commercial Backbone Distribution system vault or Main Backbone Distribution System vault to all residential, commercial, and retail buildings in the Project.

- A. The Commercial Service Distribution System consists of the following components:
- i. Distribution Conduit. A single 3” empty continuous conduit shall be installed from the nearest Commercial Backbone Distribution System vault or Main Backbone Distribution System vault to each building in the Project. Conduit will be terminated on one end at the nearest communications vault, and on the other end, within the building utilities common room (this is the “Service Entrance”).
  - ii. Inter-building Conduit. A single 3” empty continuous conduit shall be installed between any adjacent buildings in the Project with common ownership. Inter-building Conduit will be terminated at each end within the building utilities common room.
  - iii. The 3” conduit(s) will enter the building either through the foundation (preferred) or through an approved external junction box. Location shall be determined in the field and coordinated between the Builder and The Developer, or their designated representative.
- B. Multi-commercial building configurations will vary based on the size and layout of each structure. In these multi-commercial locations, Builder will coordinate all aspects of the Commercial Service Distribution system with The Developer or their designated representative, including providing (1) locations of any proposed cable routes by various vendors and (2) adequate space to locate communication hardware.
- C. The Builder will be responsible for all costs to connect buildings in the Project via Distribution Conduit and Inter-Building Conduit to the Main Backbone Distribution System vaults.

### **3. COMMERCIAL STRUCTURED WIRING SYSTEM**

This system consists of conduit connecting the service entrance of the Commercial Service Distribution System to a central communication distribution panel. This panel is in turn connected by either (a) Category 6 Ethernet wiring, or (b) 1” flexible fiber conduits to data distribution outlets located within the building. The aforementioned distribution method and specifications for commercial units and multi-family dwellings will vary depending on the size and layout of each structure. The Builder is responsible for all costs of the Commercial Structured Wiring System.

The Commercial Structured Wiring System consists of the following components:

## A. Single-Commercial Buildings

- i. Conduit. An appropriately fire-rated single 3” empty continuous conduit shall be installed from the service entrance to the central communication distribution panel. Conduit will be terminated adjacent to, or spliced onto, the service entrance conduit at one end and will be securely fastened adjacent to the central communication distribution panel at the other end.
- ii. Central Communication Distribution Panel. Space for a central communication distribution panel will be installed in an easily accessible central location within the building. Space required for the panel will vary based upon the size and layout of each structure, and must be coordinated with the Developer or their designated representative.
- iii. AC Power. Two dedicated, non-switched 20 Amp, 110VAC, non-GFCI, duplex power outlets will be provided adjacent to the central communications distribution panel and is to be allocated to HFN exclusively.

## B. Multi-Family/Multi-Commercial Buildings

Multi-family/multi-commercial building configurations will vary based on the size and layout of each structure. Smaller units will be treated as single-family/single-commercial structures, each with a separate service entrance and central communication distribution panel. Larger units will require dedicated areas within the building to accommodate communications equipment and wiring distribution systems. Coordinate installations with The Developer or their designated representative.

- i. Small Units: Refer to the Single-Commercial Buildings, Section A
- ii. Large Units
  - a. Main Communications Closets. Rooms dedicated to building’s communications equipment necessary for the Issaquah Highlands Data Network will be provided as necessary. These communication rooms will not support other communications systems and the personnel operating the Issaquah Highlands Data Network shall have 7X24 access to them. Minimum dimensions for communications closets or equipment rooms will be approved in advance by The Developer or their designated representative. These rooms will be centrally located to minimize wiring distances and will be provided with dedicated power, lighting, and environmental controls.
  - b. Conduit. Conduit will be provided from the service entrance to the Main Communications Closet. In the case of multiple closets, conduit will be provided between each closet. The size and type of conduit will be specified on a case-by-case basis.
  - c. Central Communication Distribution Panels. The central communication distribution panels for wiring distribution will be installed in each individual unit. The exact configuration will depend on the specific structure design.
  - d. AC Power. Two dedicated, non-switched 20 Amp, 110VAC, non-GFCI, duplex power outlets will be provided adjacent to the central communications distribution panel and is to be allocated to HFN exclusively..

## 4. SPECIFICATIONS

All work will comply with applicable building and electrical codes, as well as ANSI/TIA/EIA 568A, 570A and 758 (latest revision, see TABLE 1).

### A. Main Backbone Distribution System and Commercial Backbone Distribution System

- i. Large Conduit/Duct. Large conduit shall be 4" industry standard DB 120 PVC pipe with integral bell (or better) with appropriate fittings. Pipe should be in accordance with TC-6 and ASTM F512 standards: O.D. 4.5", I.D. 4.192" with minimum wall thickness .166". Conduit to be installed with the maximum bend radius possible with no 90-degree bends. Duct shall be placed with a minimum of 36" cover over the top of the highest duct. A 10 THHN locator cable shall be buried next to the conduit duct. Multiple levels of duct shall have spacers installed to maintain correct conduit location.
- ii. Medium Conduit/Duct. Medium conduit shall be 3" industry standard DB 120 PVC pipe with integral bell (or better) with appropriate fittings. Pipe should be in accordance with TC-6 and ASTM F512 standards: O.D. 3.5", I.D. 3.264" with minimum wall thickness .127". Conduit to be installed with the maximum bend radius possible with no 90-degree bends. Duct shall be placed with a minimum of 36" cover over the top of the highest duct. A 10 THHN locator cable shall be buried next to the conduit duct. Multiple levels of duct shall have spacers installed to maintain correct conduit location.
- iii. Small Conduit/Duct. 1" or 1 ¼" smooth walled polyethylene SDR-11 conduit pipe (or better) with appropriate fittings will be installed in a "quad" configuration of one or more units of 4 conduits per length of run. All conduits will have a pre-installed pull rope or tape. 1" nominal size: O.D. 1.055", I.D. 1.315", minimum wall thickness 0.120". 1 ¼" nominal size: O.D. 1.338", I.D. 1.660", minimum wall thickness 0.151". Conduit will be installed with the maximum bend radius possible with no 90-degree bends. Duct shall be placed with a minimum of 36" cover over the top of the highest duct. A 10 THHN locator cable shall be buried next to the conduit duct. Multiple levels of duct shall have spacers installed to maintain correct conduit location.
- iv. Precast Vaults. Vaults will be standard 48" x 48" x 48" deep communications vaults (Utility Vault Company 444-LA or equivalent). Vault covers will have a full 180 degree opening cover with spring assisted galvanized diamond plate covers with locking latch and a recessed lift handle (Utility Vault Company 44-332P or equivalent). Vaults will be set at grade level. Vaults must be placed upon a 4" sand/gravel drainage bed. Note: Some vaults will require pad-mounted equipment cabinets placed above the vault opening. Specifications for the placement and installations of these vaults will be provided on a case-by-case basis by The Developer or their designated representative.

## B. Commercial Service Distribution System

The service conduit coming from the street shall enter the building either through the foundation (preferred) or through an approved external junction box. In-building conduit shall be used to extend service conduit from the Service Entrance to the Central Communication Distribution Panel located at the Main Distribution Location (MDL) for the building. The service conduit must have a pull string installed for subsequent installation of communications cable.

- i. Communication service conduits coming from the backbone distribution system shall maintain the separation from power conduits or cables required by the local power company, preferably a minimum of 12".
- ii. Buried communication service conduit must be installed a minimum of 18 inches underground. A 3" wide orange warning tape shall be buried at least 12" below ground level and approximately 6" over the conduit ducts.

- iii. Buried communication service conduit shall have watertight connections and be sloped properly so water will drain away from the building entrance.
- iv. It shall be the responsibility of The Developer to install conduit up to the property line for each subdivision. It shall be the responsibility of the Builder to install and connect conduit from the property line up to the unit(s).
- v. HFN, or their designated representative, will install fiber cable from the backbone distribution system to the central communications distribution panel using the service conduit when the network is installed.
- vi. All Service Distribution System conduits shall be labeled identically at both ends with a unique identification utilizing permanent ink.

C. Vault/Conduit Drainage

- i. All vaults will be set upon a bed of gravel and/or sand.
- ii. Drain holes will be installed within vaults with solid bottoms as necessary to drain off ground water.
- iii. Duct plugs shall be installed in all conduits. Duct plugs shall have minimum 20 psi sealing capacity.

D. Commercial Structured Wiring System

i. Central Communications Distribution Panel-Requirements

- a. The central communications distribution panel is the distribution point for all horizontal data cable in the commercial structure. Placement should allow easy access for the service personnel. Exact dimensions for the central communications panel vary with the size and layout of the structure, and must be coordinated with the Developer or their representative.
- b. The central communication distribution panel shall be installed where the normal ambient temperatures do not go below 32 degrees F, or above 110 degrees F.
- c. Two (2) dedicated 20-amp, 110VAC, non-GFCI, electrical circuits shall be installed adjacent to the central communication distribution panel. These circuits are required exclusively for data service and communication equipment supplied by HFN. The circuits shall be terminated in duplex electrical outlets.
- d. The data panel location shall have at least (1) one additional duplex electrical outlet nearby for tools, diagnostic and test equipment. This outlet can be part of a shared 20-amp circuit.
- e. All equipment shall be grounded according to TIA/EIA-607 standards for grounding, and electronically isolated from one another.

ii. Central Communications Distribution Panel-Other Parameters

In the event that the central communications distribution panel is used to serve other utility services, separate and clearly delineated areas in the central communications distribution panel shall be used for video, telephone, and data cable termination equipment. Individual cable terminations must be clearly coded, tagged and identified according to IEEE standards.

- a. Fiber Optic service cable is installed from the backbone distribution system vault to the central communications distribution panel.

- b. All communications equipment will be mounted inside the central communications distribution panel and will require electrical power.
  - c. A service loop of 24” (minimum) shall be neatly looped and secured within the central communications distribution panel.
  - d. All installations shall conform to the latest ANSI/TIA/EIA/568A and 570A standards (see TABLE 1).
- iii. Equipment Rooms (Multi-family/Commercial only)
- Equipment rooms or communications closets are special-purpose rooms that provide space and a suitable operating environment for communications and/or computer equipment, and will be provided with sufficient space to house standard 19” equipment racks and sufficient working space. Provision should also be made for the installation of a backboard for equipment mounting. The Builder should coordinate the design with The Developer or its representative. Equipment rooms should be furnished with the following:
- a. Power. Minimum of two dedicated 110VAC / 20-amp, non-GFCI, power terminated on 4-plex outlets to be used for HFN purposes exclusively.
  - b. Lighting. Sufficient lighting for a normal working environment.
  - c. HVAC. The equipment rooms or communications closets shall have normal ambient temperatures maintained between 32 degrees F and 110 degrees F.

## 5. STANDARDS

### Reference Codes and Standards

- A. The publications listed below form a part of this specification to the extent referenced. The publications are referred to in the text by basic designation only, latest edition. The reference codes and standards are minimum requirements.

TABLE 1

Reference	Title/Revision
ANSI/ICEA S-80-576	Communications Wire and Cable for Wiring of Premises
ANSI/ICEA S-83-596	Fiber Optic Premises Distribution Cable Technical Requirements
ANSI/ICEA S-87-640	Fiber Optic Outside Plant Communications Cable
ANSI C2	National Electrical Safety Code
ANSI/NFPA 70	National Electrical Code
ANSI T1.318	Electrical Protection Applied to Telecommunications Network Plant at Entrances to Customer Structures or Buildings
ANSI/TIA/EIA-568-A	Commercial Building Telecommunication Cabling Standard (October 1995)
ANSI/TIA/EIA-569	Commercial Building Standards for Telecommunications Pathways and Spaces (October 1990)
ANSI/TIA/EIA-570A	Residential Telecommunications Cabling Standard
ANSI/TIA/EIA-571	Environmental Considerations for Telephone Terminals

<b>Reference</b>	<b>Title/Revision</b>
ANSI/TIA/EIA-606	Administration Standard for the Telecommunications Infrastructure of Commercial Buildings (February 1993)
ANSI/TIA/EIA-607	Commercial Building Grounding and Bonding Requirements for Telecommunications
ANSI/TIA/EIA-758	Customer-Owned Outside Plant Telecommunications Cabling Standard
ANSI/TIA/EIA-TSB 67	Transmission Performance Specifications for Field Testing of Unshielded Twisted-Pair Cabling Systems (October 1995)
ANSI/TIA/EIA-TSB 72	Centralized Optical Fiber Cabling Guidelines (October 1995)
ANSI/TIA/EIA-TSB 95	Additional Transmission Performance Guidelines for 4-pair 100 Ohm Category 5 Cabling
BICSI TDMM	Telecommunications Distribution Methods Manual
BICSI CO-OSP	Customer Owned Outside Plant Design Manual